



INTELLIREAM® DD-IOL

DIRECT DRIVE ROBOTIC TORCH MAINTENANCE CENTER

Extend the life of your robotic MIG torch and improve cycle time in your robotic welding cell with the Nasarc Intelliream® DD-IOL (IO-Link™) model. Designed to improve overall welding equipment effectiveness, this robotic torch maintenance center systematically removes and limits spatter accumulation for enhanced productivity.

The Intelliream® DD-IOL model provides additional functionality including enhanced command and diagnostic signals. The complete process is managed by the internal CPU.

PRODUCT ADVANTAGES

Automated Nozzle Reamer:

- Independent reaming cycle uses a high-strength coated reaming bit designed to effectively remove and discard spatter from the nozzle. A two stage de-ringer removes the spatter ring at the bottom of the nozzle before reaming. The automatic retry feature ensures the nozzle is reamed to full depth.

Automated Wire Cutter:

- The innovative pinch-off wire cutter design creates a "V" shape for optimal arc starts. It is powerful and precise enough to handle all wire sizes up to 1/16" mild steel.

Automated Anti-Spatter Sprayer:

- Vortex action sprayer delivers a radial spray pattern to uniformly coat the interior surface of the nozzle and help prevent spatter buildup. The anti-spatter fluid reservoir may be mounted remotely.

Nozzle Gas Flow Sensor:

- Designed to detect and measure adequate gas flow at the point of use.

Nozzle Presence Sensor:

- Post-cleaning, presence sensor ensures the nozzle is secured and ready for the next weld.

Intuitive User Interface:

- Designed to allow for easy setup, diagnostics and reporting at point of use.

TECHNICAL DATA

Footprint Size:	19" H x 12" L x 10" W
Cutter Speed:	320 RPM
Air Driven Motor:	0.5 HP
Wire Cutter Diameter:	0.030" - 0.0625"
Air Supply:	80 PSI, 17 SCFM
Power Supply:	24 VDC, 0.3A*

PROCESS HIGHLIGHTS

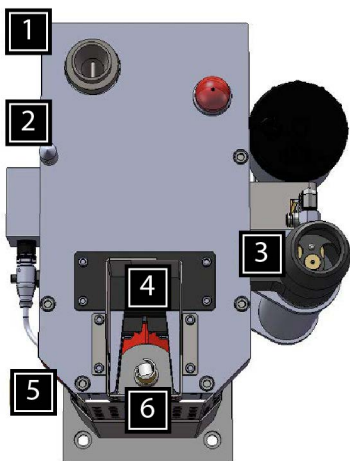

- 01** Nozzle gas flow sensor detects gas flow at the point of use.
- 02** TCP check pin verifies positional accuracy of the tool center point.
- 03** Vortex action sprayer delivers a radial spray pattern to uniformly coat the interior surface of the nozzle.
- 04** Pinch-off wire cutter is integrated in the clamp housing for easy and quick access, minimizing cobot movement.
- 05** Nozzle detect ensures that the nozzle is fastened on the torch.
- 06** Automated reaming cycle uses a high-strength coated reaming bit.

PERFORMANCE

The networked Intelliream® DD-IOL provides additional performance over traditional reamers.

- Ease of installation and seamless integration with controller.
- I/O Link™ is available as a port class A device.
- Troubleshooting via diagnostics at the robot or PLC.
- Expandable platform for feature upgrades.
- Single connection for multiple robots.
- Data acquisition of process counters.
- *Ensure the IO-Link Hub used is capable of supplying at least 0.3A per each device port. Contact Nasarc sales for optional power supply configurations.

IO-Link Interface Wiring

1. +24 VDC Control	(BRN)
2. Input 1	(WHT)
3. 0 VDC Control	(BLU)
4. C/Q IO-Link	(BLK)

INDUSTRY 4.0 FEATURES & BENEFITS

The INTELLIREAM® DD-IOL torch maintenance center incorporates the following advantages enabled by network connectivity:

- Cycle counter and preventive maintenance countdown will boost uptime and improve overall equipment effectiveness.
- Add-on instruction (AOI) is available for Logix PLCs to cut integration time and costs.
- Magnetic sensors are utilized for optimum position accuracy and reliability.
- Dry-run and sensor override modes make setting up and trouble-shooting easier.
- Self-centering grip design for positive traction on all nozzle sizes.
- On-board diagnostics indicate position and fault codes for ease of troubleshooting.
- A status light signals when the unit is operating and flashes diagnostic codes if a fault occurs.
- Advanced diagnostic and troubleshooting tools help pinpoint issues and decrease downtime.

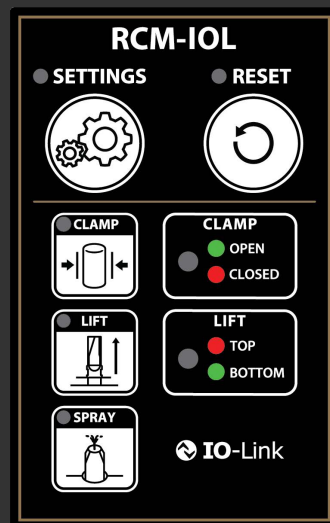

FLEXIBLE MOUNTING OPTIONS

There are 2 mounting options.

- 1) Mounting Box - A mounting box can be used to mount on any fixture or table.
- 2) Floor Mount Stand (various heights available)

ORDERING INFORMATION

STANDARD EQUIPMENT

INTELLIREAM® DD-IOL
Spray System
TCP Check Pin
Status Light
De-ringer
Fluid Reservoir

IRM040001-DD-IOL

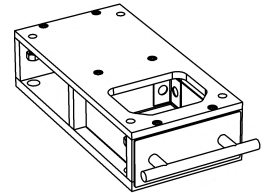
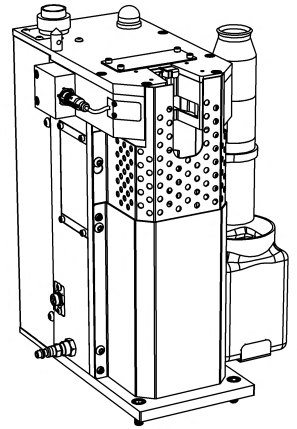

FACTORY INSTALLED OPTIONS

Mounting Box
Mounting Box Tray
Mounting Box Adapter (IRM02/IRM03)
Wire Cutter
Nozzle Detect Assembly
Nozzle Gas Flow Sensor

IRX120099-00
IRX120099-01
IRX120099-02
IRW010099-00
IRE120099-02
NAC40A

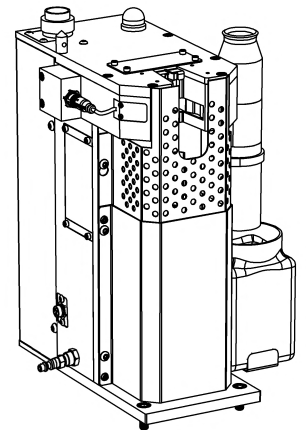

ACCESSORIES

Reaming Bit, 1/2"
Reaming Bit, 1/2" Bottleneck
Reaming Bit, 15.5mm
Reaming Bit, 5/8"
Reaming12 Bit, 3/4"
IO-Link Cable, 4 pin, 10m
Floor Mount Stand, 30" DD
Anti Spatter Bulk Feed DD

IRB010500-00
IRB010501-00
IRB01M155-00
IRB020625-00
IRB010750-00
IRE060017-00
IRX120099-30
IRS120099-06

